



N. K. PUBLIC SCHOOL



HOLIDAY HOMEWORK

MAY 18 - JUNE 21

BEST TIME TO LEARN A NEW SKILL

Wishing you days
filled with fun,
creativity, and
laughter

FAMILY

**SCREEN
FREE**

PLAY & LEARN

**MAKE
FRIENDS**

**Let your child enjoy a holiday
packed with games, crafts,
music, and new friends!**



Dear Parents,

Summer holidays are not just a break from schoolwork; they are a beautiful opportunity for children to slow down, explore life beyond textbooks, and grow in ways that classrooms alone cannot offer.

This year, we encourage a **screen-free and meaningful summer** for our students. Let this vacation be filled with **curiosity, creativity, and connection**. Encourage your child to learn a **new skill, discover a hobby, help at home, observe nature, and ask questions** about the world around them.

More importantly, let this be a time for **family bonding**. Spend unhurried moments together. Talk, laugh, and share stories.

Give your child the warmth of your presence – sometimes a **simple hug reassures them more than a hundred words**.

We request parents to nurture a few small but powerful habits during these holidays:

- **Read a story to your child every night.** Books open windows to imagination and values.





- **Make meals a family time.** Sit together, talk about the day, and create memories.
- **Encourage conversations rather than screens.** Childhood is too precious to be spent scrolling.
- **Appreciate their efforts and celebrate small learnings.**

Remember, the greatest gift we can give our children is **our time, attention, and love.**

The holiday homework shared with you is designed to be **joyful, creative, and experiential** rather than burdensome. We hope these activities will help children return to school with **new skills, happy memories, and brighter smiles.**

Wishing all our students and families a **safe, joyful, and meaningful summer vacation.**

Warm regards,

Principal

N. K. Public School



नाम: _____

तिथि: _____

अक्षर को चित्र से मिलाओ

अ

.

.



आ

.

.



इ

.

.



ए

.

.



ऊ

.

.



उ

.

.



NAME: _____

DATE: _____

Match the Letters

Draw a line by connecting the dots to match the uppercase letter to its matching lowercase letter.

A •

• d

B •

• c

C •

• e

D •

• b

E •

• a

Circle the correct Letter (A – E)



B A C D E

A B C D E



E D A B C

B A C D E



A B E D C

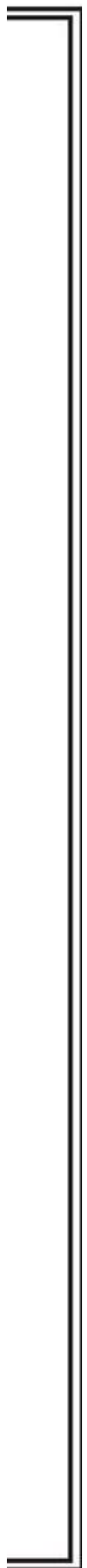

Name: _____

Date: _____

Big Or Small ?

Color the small object blue and big object red.



हस्ताक्षर :

३

दिनांक :

Name : _____

Inside and Outside

Observe each picture, and check the option that best describes the position of the object in it.

1)



inside outside

2)



inside outside

3)

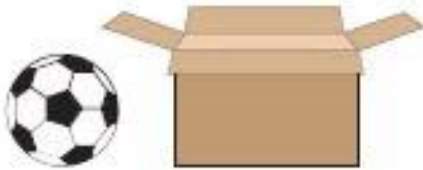

inside outside

4)



inside outside

5)



inside outside

6)



inside outside

7)



inside outside

8)





inside outside

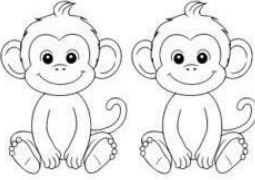
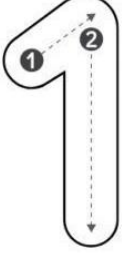

ONE



TWO



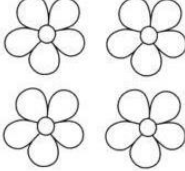
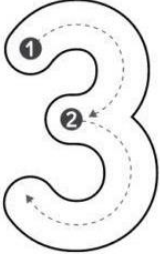

THREE

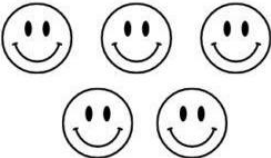
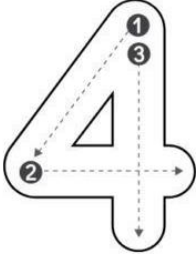

FOUR

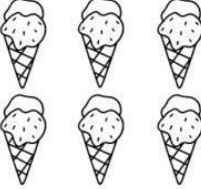

FIVE



SIX

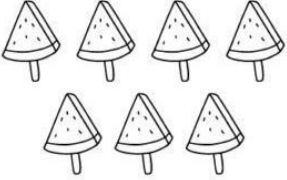
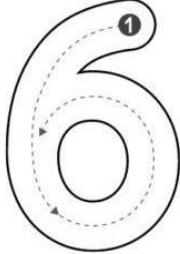

SEVEN

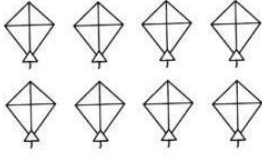
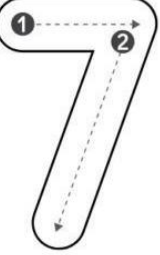

EIGHT

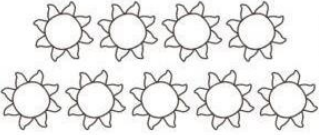
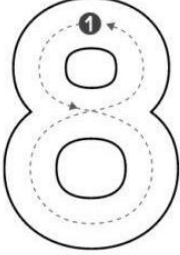

NINE

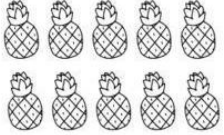
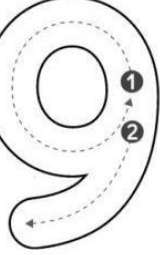

TEN

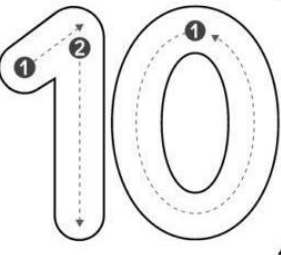

Name: _____

I can trace lines.

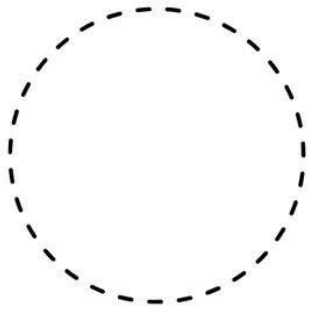

Circle



Square



Triangle



Heart

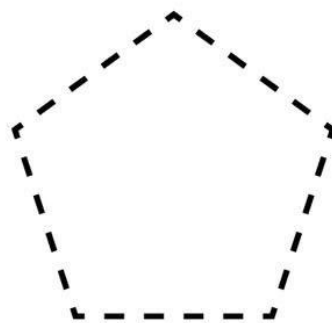

Pentagon



Star

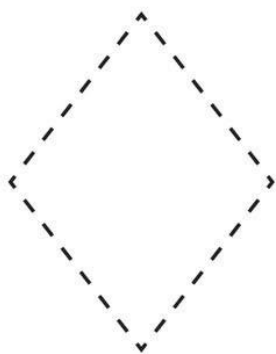

Diamond

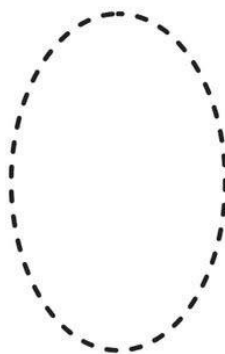

Oval



Rectangle

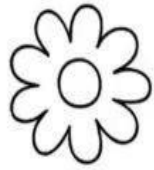

ALL ABOUT ME



My Name is:

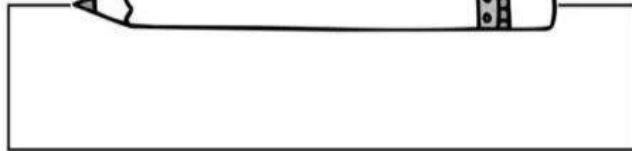

This is a Picture of Me

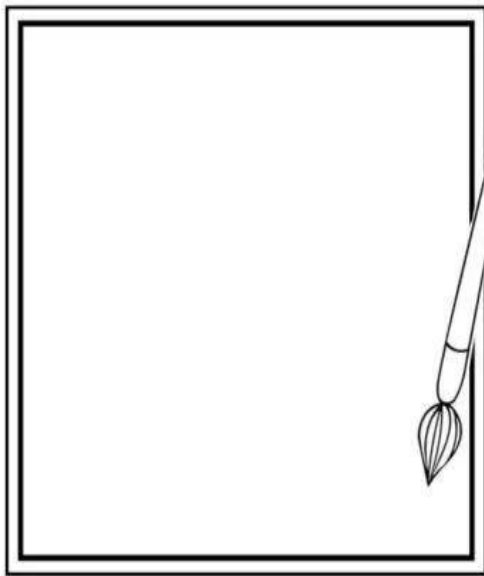

I am _____ years old

My Birthday is:

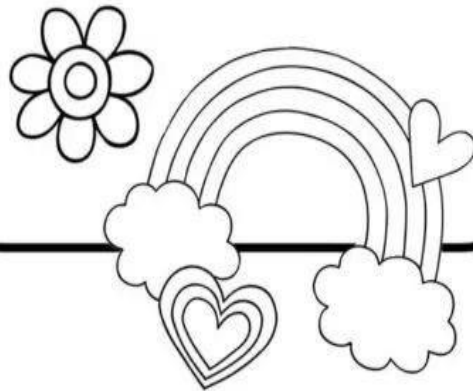

My Favorite Color is:



I love to eat:

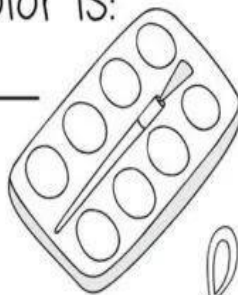

My Favorite Activities: